

LAMOT[®]

BRAND PRODUCTS

PRODUCT SELECTION GUIDE

SINCE 1964

- RUPTURE DISCS
- HOLDERS
- SPECIAL APPLICATIONS

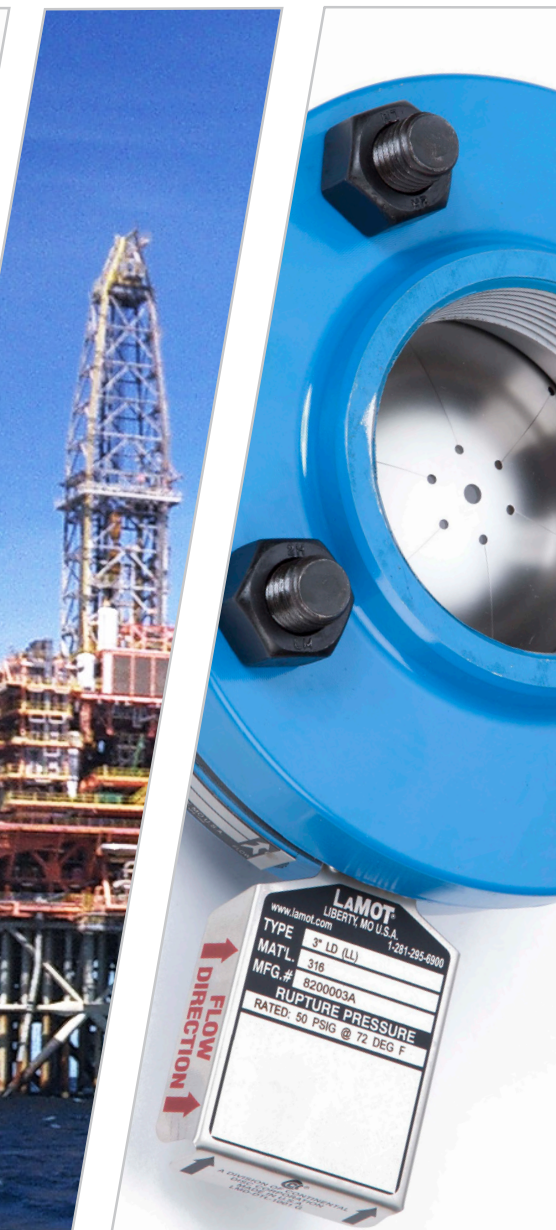

PRODUCT SELECTION GUIDE

LAMOT[®]
BRAND PRODUCTS

LAMOT QUALITY RUPTURE DISCS



Since 1964, the LaMOT brand of rupture discs and rupture disc holders have been manufactured using proven techniques, industry standards, and modern manufacturing methods.

As a customer, we know you expect both product quality and dependable service. When you choose LaMOT Brand Products, this is precisely what you receive.

All manufacturing is performed under an approved ISO 9001 Quality Assurance System which ensures that rupture discs and holders are built to exacting specifications.

Our sales team is ready to offer immediate assistance when you need an answer, have a problem to solve or an order to place.

QUALITY

When you choose the LaMOT Brand Products, there are three advantages you can count on with every order:

- > Highest Quality
- > Quick Deliveries
- > Value for the Money

Rupture disc holders are manufactured using computer controlled equipment, thus ensuring quality finishes and dimensional accuracy. Our rupture discs are manufactured from a variety of metals which are purchased according to closely controlled specifications.

Special metal forming techniques and state-of-the-art pressure indicators insure very accurate recorded rupture pressures. This, in combination with our years of manufacturing experience and dedication to quality, is assurance of precision performance from LaMOT Brand Products.

Inquiries about rupture disc applications requiring special designs are encouraged.

WHAT'S INSIDE...

TABLE OF CONTENTS

EDUCATION

Standard Rupture Discs	4
Seating Configurations.....	4
Composite Rupture Discs	5
Burst Rating Types	6 & 7
Temperature Table	7
Rupture Disc Selection Tree.....	8
Certifications	9
Tags	9

OPTIONS & ACCESSORIES

Protective Rings	9
Dent Protectors	9
Vacuum Supports	9
Handling Supports	9
Gaskets.....	9

STANDARD RUPTURE DISCS

30° Angular Seat Standard.....	10
Flat Seat Standard.....	10

COMPOSITE RUPTURE DISCS

Flat Seat LDV-G	10
Isolation Seal Rupture Discs	10
30° Angular Seat LD	11
30° Angular Seat LDV	11
30° Angular Seat LPL.....	11
30° Angular Seat LPLV	11

ALARM SYSTEMS

BDI-FLX® Burst Disc Sensor System.....	15
B.D.I.® Alarm System	15

HOLDERS

Insert.....	17 & 18
Full-Bolted	17 & 19
Union Type.....	17 & 20

RUPTURE DISC ASSEMBLIES

Screw Type Assembly.....	21 & 22
Throwaway Assembly.....	21 & 23

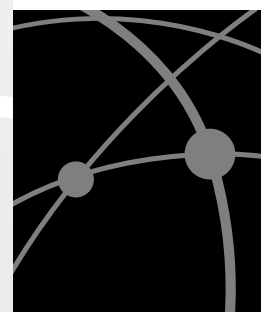

STANDARD RUPTURE DISCS

STANDARD TYPE RUPTURE DISCS

The **Standard Rupture Disc** is a solid metal, prebulged (preformed) differential pressure relief device. It is widely used in industry to protect equipment, vessels, and systems from an overpressure condition. The rupture disc provides instantaneous full-opening within milliseconds of an overpressure situation. The LaMOT Brand standard rupture disc provides performance under pressure and is the guardian of the system.

SIZES AND MATERIALS

The 30° angular seat design Standard Rupture Disc is available in nominal sizes 1/2" through 12" (13 - 300 mm) for use in Full Bolted, Insert and Union rupture disc holders.

Pressure ranges from 3 psig to 6,000 psig (0,207 - 414 barg) are available in a variety of different materials. The available burst pressures for the Standard Rupture Disc are found in **Table 4**. Depending on the material of construction, this rupture disc will perform at temperatures up to 1,000°F (538° C) and resist most corrosive media and atmospheric conditions. Refer to **Table 3** for recommended maximum operating temperatures of Standard Rupture Disc materials.

The Standard Rupture Disc is suitable for either gas/vapor or liquid applications. The Standard Rupture Disc is ideal for static, pulsating or cyclic operation condition, but requires a vacuum support to withstand vacuum.

The Standard Rupture Disc is used in systems that have an operating pressure that does not exceed the maximum recommended operating ratio of 70% of the rupture disc's marked burst pressure. The Standard Rupture Disc has a full-opening and fragmenting design for optimum flow and reliable performance that make it an ideal choice for primary and/or secondary system relief protection.

The Standard Rupture Disc is available to be cleaned for oxygen or chlorine service. Other rupture disc options are available for the Standard Rupture Disc such as protective rings, gaskets, handling supports, dent protectors and vacuum supports. For more information on these items, see page 9.

CORROSION PROTECTION

When a rupture disc is subjected to corrosive elements from either the media or atmospheric side, the LaMOT Brand offers both protective liners and coatings to help eliminate the effect corrosives might have on the performance of the rupture disc. Typically, liners are made of fluoropolymer.

SEATING CONFIGURATIONS

The LaMOT Brand Standard Rupture Disc is available in a 30° angular "Light-Lip" seat and a 30° angular "Heavy-Lip" seat. Size and rupture disc holder bolting class determine the seat design. Refer to **Table 1** for information on application of Heavy-Lip seating. Seating not indicated in **Table 1** as Heavy-Lip, will be Light-Lip.

Table 1 // Usage for Heavy-Lip Seating Design

Nominal Size	Holder Bolting Class		
	ASME	DIN	JIS
1/2 in	1500 & up		
13mm		250 & up	-
1 in	1500 & up		
25mm		250 & up	-
1 1/2 in	900 & up		
40mm		160 & up	-
2 in	900 & up		
50mm		160 & up	-
3 in	1500 & up		
80mm		250 & up	-
4 in	1500 & up		
100mm		250 & up	-

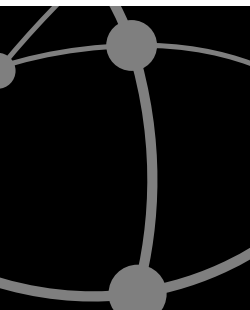

COMPOSITE TYPE RUPTURE DISCS

The **Composite Rupture Disc** is constructed of two or more components of metallic and/or non-metallic materials. It is a differential pressure relief device used for protecting equipment, vessels and systems from an overpressure condition.

The Composite Rupture Disc provides a number of outstanding features:

- Excellent low pressure capabilities
- Non-fragmenting design, when used with non-metallic seals
- 80% maximum recommended operating ratio, flat designs offer a 50% maximum recommended operating ratio
- Excellent for gas/vapor or liquid service
- Three-dimensional flow tag

SIZES AND MATERIALS

The 30° angular seat design Composite Rupture Disc is available in sizes ranging from 1" through 12" (25 - 300 mm) for use in Full Bolted, Insert and Union rupture disc holders.

Pressure ranges from as low as 2 psig through 1,440 psig (0,138 - 99,3 barg) are available in a variety of different materials. Refer to **Table 5** for available burst pressures for the Composite Rupture Disc.

Because of the availability of a variety of different seal materials, the Composite Rupture Disc can perform at temperatures up to 1,000°F (538°C) and resist most corrosive and atmospheric conditions. Refer to **Table 3** for recommended maximum operating temperatures of Composite Rupture Disc materials.

The Composite Rupture Disc is recommended for use in systems that have a maximum operating pressure of up to 80% of the rupture disc's marked burst pressure. The Composite Rupture Disc is ideal for static, pulsating or cyclic operation condition, but requires a vacuum support to withstand vacuum.

The Composite Rupture Disc is an ideal choice for primary and/or secondary system relief protection and the non-fragmenting design provides an effective means of fugitive emission control when used to isolate a safety relief valve.

CORROSION RESISTANT

The design of the Composite Rupture Disc allows for the use of highly corrosion resistant seal materials, such as fluoropolymer or exotic metallic materials. This is possible because the burst rating of the rupture disc is determined by the slotted metal top section. Therefore, the seal or liner can be made of thin corrosion resistant materials and still provide a wide range of burst pressures.

SEVEN-HOLE PATTERN

The LaMOT Brand Composite Rupture Disc top section is manufactured with a seven-hole pattern at the apex of the rupture disc dome. This seven-hole pattern, along with the six pre-cut sections, provides a non-fragmenting design when used with a non-metallic or fluoropolymer seal.

With the seven-hole pattern, heavier materials of construction can be used. This results in a higher maximum recommended operating ratio – up to 80%.

When ordering a Composite Rupture Disc, specify when your application requires the use of a non-fragmenting design rupture disc.

The Composite Rupture Disc is available to be cleaned for oxygen or chlorine service. Other rupture disc options are available for the Composite Rupture Disc such as protective rings, gaskets, handling supports, dent protectors and vacuum supports. For more information on these items, see page 9.

COMPOSITE RUPTURE DISCS

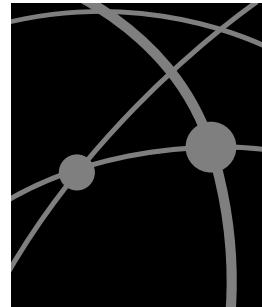

LAM
LIBERTY, M
www.lamot.com

TYPE 3" LD (LL)

MANUFACTURING RANGES

BURST RATING TYPES

Manufacturing ranges are shown in **Table 2** for LaMOT Brand Products. Special and reduced manufacturing ranges are available upon request. For Burst Tolerances and Recommended Operating Pressure see **Table 2A**. **Tables 2** and **2A** are based on the RATED Rating Type. Specified and MIN/MAX Rating Types are also available.



FOR MORE INFORMATION REGARDING RUPTURE DISC RATING, RANGE AND TOLERANCES, PLEASE SEE THE: **BURST RATING TYPES DATASHEET**

Table 2 // Manufacturing Ranges

Product	Requested Rated Burst Pressure	Standard Manufacturing Range
STD, LD, LDV, LPL and LPLV	above 500 psig above 34,5 barg	-3% / +6%
	above 100 up to and including 500 psig above 6,89 up to and including 34,5 barg	-4% / +7%
	above 50 up to and including 100 psig above 3,45 up to and including 6,89 barg	-4% / +10%
	above 19 up to and including 50 psig above 1,31 up to and including 3,45 barg	-4% / +14%
	above 12 up to and including 19 psig above 0,827 up to and including 1,31 barg	-10% / +20%
	above 8 up to and including 12 psig above 0,552 up to and including 0,827 barg	-30% / +30%
	up to and including 8 psig above 0,345 up to and including 0,552 barg	-40% / +40%
IS-1 and IS-2	All Pressures	ZERO



STANDARD & COMPOSITE RUPTURE DISCS

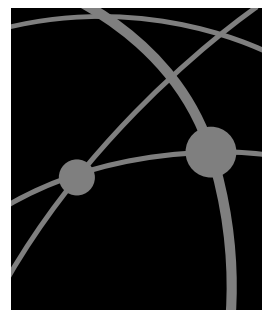

Table 2A // Burst Tolerances and Maximum Recommended Operating Pressures

Product	Rated (Marked) Burst Pressure	Burst Tolerance Around Rated (Marked) Burst Pressure	Maximum Recommended Operating Pressure
STD, LD, LDV, LPL and LPLV	above 40 psig above 2,76 barg	-5% / +5%	For STD 70% of Rated (Marked) Burst Pressure
	above 14 up to and including 40 psig above 0,965 up to and including 2,76 barg	-2 psig / + 2 psig -0,138 barg / + 0,138 barg	
	above 12 up to and including 14 psig above 0,827 up to and including 0,965 barg	-10% / +10%	
	above 8 up to and including 12 psig above 0,552 up to and including 0,827 barg	-15% / +15%	For LD, LDV, LPL, & LPLV 80% of Rated (Marked) Burst Pressure
	above 5 up to and including 8 psig above 0,345 up to and including 0,552 barg	-20% / +20%	
	up to and including 5 psig up to and including 0,345 barg	For STD -25% / +25% For LD, LDV, LPL & LPLV -20% / +20%	
IS-1 and IS-2	above 40 psig above 2,76 barg	-5% / +5%	50% of Rated (Marked) Burst Pressure
	above 14 up to and including 40 psig above 0,965 up to and including 2,76 barg	-2 psig / + 2 psig -0,138 barg / + 0,138 barg	
	above 12 up to and including 14 psig above 0,827 up to and including 0,965 barg	-10% / +10%	
	above 10 up to and including 12 psig above 0,689 up to and including 0,827 barg	-13% / +13%	
	above 8 up to and including 10 psig above 0,552 up to and including 0,689 barg	-15% / +15%	
	above 5 up to and including 8 psig above 0,345 up to and including 0,552 barg	-20% / +20%	
	up to and including 5 psig up to and including 0,345 barg	-25% / +25%	

RECOMMENDED MAXIMUM TEMPERATURES

Normally, the burst pressure of a rupture disc will decrease as the operating temperature increases. **Table 3** states the maximum temperatures for commonly used rupture disc materials, seals, liners and coatings.

Table 3 // Maximum Temperature for Rupture Disc Materials, Liners & Coatings

Materials	Temperature Limit	
	°F	°C
Aluminum / Silver	260	127
Nickel / MONEL®	800	427
316 SS / HASTELLOY® C	900	482
INCONEL®	1,000	538
FEP Fluoropolymer Seal, Liner or Coating	400	204
PTFE or PFA Fluoropolymer Seal or Liner	500	260



RUPTURE DISC SELECTION TREE

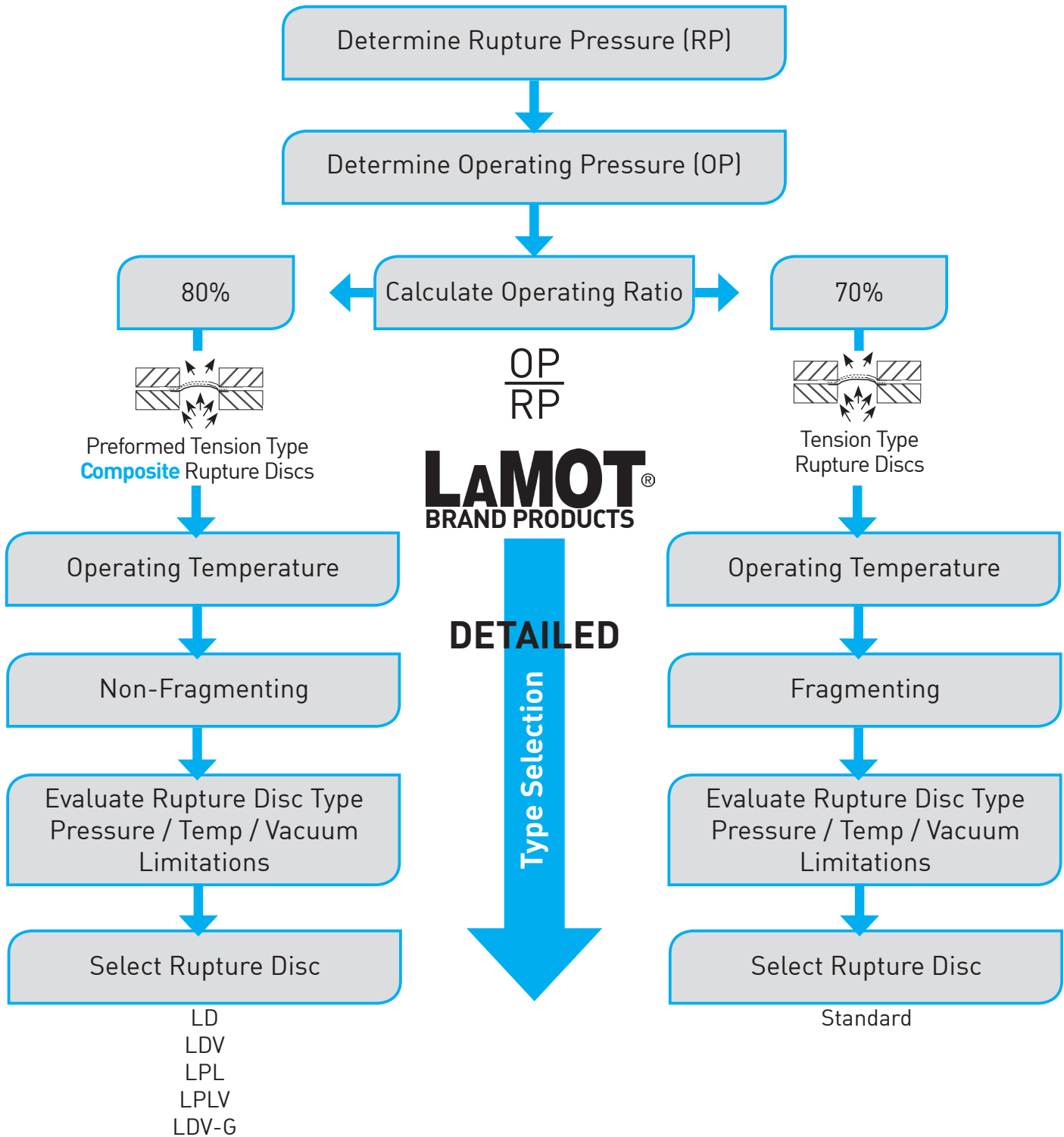

Don't Forget to Consider:

- > Liquid/Vapor Service
- > Primary/Secondary/Relief Valve
- > Material Requirements (Corrosion, Temperature, Cost)
- > Other Factors May Apply When Choosing A Rupture Disc

RUPTURE DISC OPTIONS

Each rupture disc application has its own unique operating conditions. Factors such as cycling and ratio of operating pressure must be considered to obtain maximum service life. The range of materials available for Standard or Composite rupture discs, combined with optional protective liners, vacuum supports, and protective rings, provide a wide selection of rupture discs for any application.

Protective Rings — Protective rings may be used on rupture discs made of thinner materials or in instances where delicate liners are used. These rings protect the rupture disc from foreign material in the seating area. Protective rings also enable easier handling of rupture discs during installation.

Gaskets — Gaskets may be used on the process side of the rupture disc to enhance sealing where scratches or pits have occurred in the seating area of the holder. A gasket lines the seating area of the rupture disc, improving sealing capability, provided the holder has been properly cleaned according to product installation instructions.

Handling Supports — To aid in the handling of rupture discs that are made of thin materials and help prevent damage during installation, an optional attached handling support can be supplied. This helps protect the product from damage that could affect the burst pressure setting of the rupture disc.

Dent Protectors — For situations where the outlet (vent side) dome of the rupture disc may require protection from physical environmental elements, an optional dent protector can be supplied to minimize damage.

Vacuum Supports — Due to the thinness of some rupture disc materials, it is necessary to support a rupture disc when a system vacuum occurs. Vacuum supports are available that will withstand a full system vacuum, eliminating damage to the rupture disc and ensuring proper operation. For backpressure conditions higher than 14.7 psig (1,01 barg), consult your local representative or the factory. When ordering a Standard or Composite rupture disc that will be subjected to a vacuum condition, clearly specify the exact conditions that the rupture disc will encounter. Vacuum supports will be supplied when specified. Vacuum supports are manufactured to mate with a specific rupture disc and are permanently attached to ensure proper installation.

ASME CERTIFICATION

Continental Disc Corporation has been authorized by the ASME to utilize the ASME Code Symbol Stamp for product built in accordance with the requirements of the ASME Boiler and Pressure Vessel Code, Section VIII, Division 1.

The flow performance of LaMOT Brand Rupture Discs was certified by The National Board of Boiler and Pressure Vessel Inspectors. These certified flow resistance (K_R) and minimum net flow area values are available from Continental Disc Corporation or The National Board of Boiler and Pressure Vessel Inspectors.

When specified, LaMOT Brand Rupture Discs will be manufactured in accordance with ASME Code Section VIII, Division 1 or other codes as required. The rupture discs will be manufactured, temperature tested and marked to comply with specific code requirements.

3-D FLOW DIRECTION TAG

The LaMOT Brand three dimensional (3-D) flow direction tag provides instant visual verification that the rupture disc has been correctly oriented into the system. The 3-D tag extends beyond the holder to insure clear visibility for easier installation and inspection after the rupture disc has been installed.

Tags, as a standard, are attached to all Standard and Composite rupture discs 1" (25 mm) nominal size and above. Tags cannot be attached to a rupture disc intended for use in a Screw Type or Throwing Holder. Tags can be attached, on request, to rupture discs for use in a Union Type Holder. Contact the factory for more details.

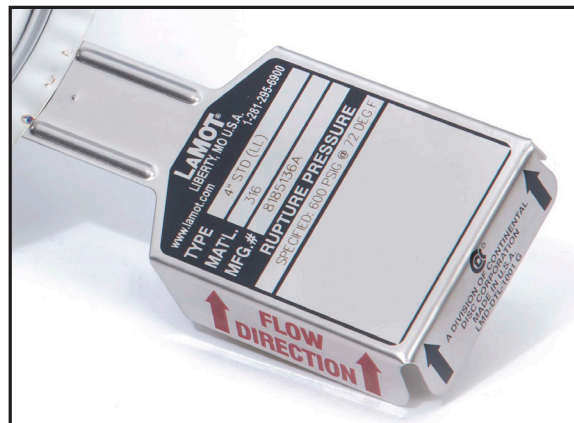

OPTIONS & ACCESSORIES

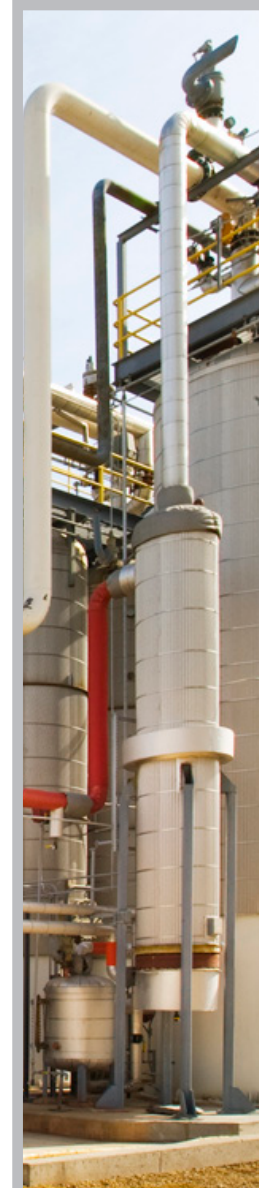
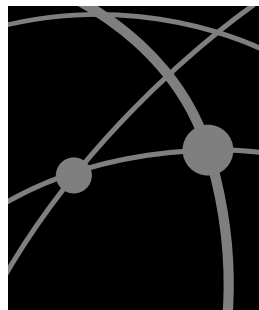

RUPTURE DISC OVERVIEW

STANDARD RUPTURE DISCS



STANDARD RUPTURE DISC (STD)

The Standard Rupture Disc (STD) is a solid metal, prebulged (preformed) differential pressure relief device. It is widely used in industry to protect equipment, vessels, and systems from an overpressure condition. The rupture disc provides instantaneous full-opening within milliseconds of an overpressure situation.



STANDARD RUPTURE DISC FOR SCREW TYPE & THROWAWAY HOLDERS

Like the 30° angular seat Standard Rupture Discs, the 1/2" and 11/16" flat seat Standard Rupture Disc's maximum recommended operating ratio is 70% of the rupture disc's marked burst pressure. Depending on the material of construction, the 1/2" or 11/16" Standard Rupture Disc will perform at temperatures up to 1,000°F (538°C). The 1/2" and 11/16" Standard Rupture Discs are suitable for liquid or gas processes.

COMPOSITE RUPTURE DISCS

LDV-G FLAT SEAT COMPOSITE RUPTURE DISC FOR SCREW TYPE & THROWAWAY HOLDERS

The 11/16" LDV-G Composite Rupture Disc is a flat seat design consisting of a metal top section, a fluoropolymer or metallic seal, metal vacuum support and a CHEMFILM® gasket. The 11/16" LDV-G Rupture Disc is available to a maximum burst pressure of 1,000 psig (68,9 barg). This rupture disc offers lower burst pressure capabilities and a higher operating ratio than the 1/2" or 11/16" Standard Rupture Disc. It is suitable for systems operating up to 80% of the rupture disc's marked burst pressure and a maximum operating temperature of 500°F (260°C). The 11/16" LDV-G Rupture Disc is comprised of a metal top section, seal and a vacuum support. It is excellent for use in services handling liquid and/or gas process.



ISOLATION SEAL (IS) RUPTURE DISC

The Isolation Seal (IS) Rupture Disc is a flat, composite designed rupture disc that installs between standard bore, 150# ASME bolted flanges. This rupture disc is not prebulged but flat. The maximum recommended operating pressure is 50% of the rupture disc's minimum burst pressure. Flat, non-asbestos gaskets are permanently affixed to the rupture disc's process and vent sides for easy handling and installation. There is no holder required.

The "IS" series rupture disc is typically used for:

- Low pressure relief of atmospheric storage tanks
- Downstream relief valve manifold isolation
- Corrosion barrier
- Environmental seal

The recommended maximum temperature for an "IS" Rupture Disc with fluoropolymer seal is 400°F (204°C). Standard sizes range from 1" through 12" (25 - 300mm). As a standard, the "IS" Rupture Disc is manufactured with a top section of 316 SS, INCONEL®, MONEL® or Nickel with a fluoropolymer seal and a non-asbestos gasket on each side of the rupture disc. Polyethylene seals may be used for low pressures. Two designs are available in the flat "IS" Rupture Disc:

- IS-1 Bursts in one direction only
- IS-2 Bursts at an identical rating in both directions

For manufacturing ranges, refer to [Table 2](#). For burst tolerances and maximum recommended operating pressures, refer to [Table 2A](#). For available burst pressures, refer to [Table 7](#).

COMPOSITE RUPTURE DISCS

RUPTURE DISC OVERVIEW

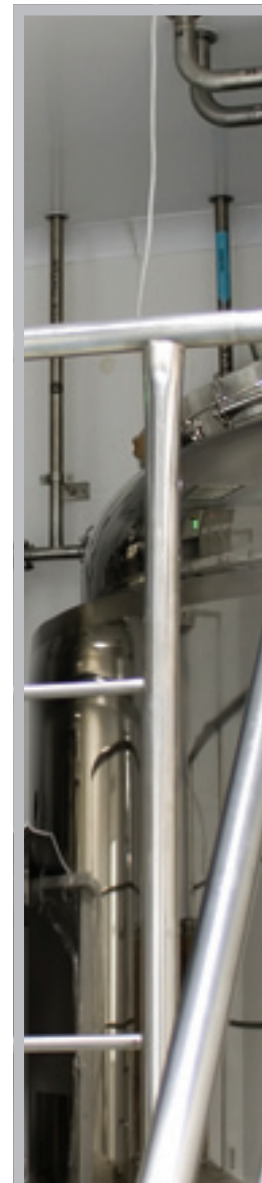
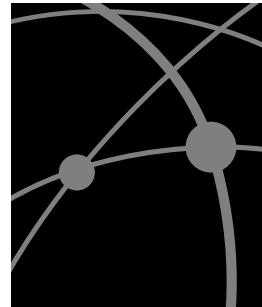

LD RUPTURE DISC

The LD is the basic Composite Rupture Disc and consists of a slotted metal top section, with a fluoropolymer or metallic seal on the process side.



LDV RUPTURE DISC

The LDV Rupture Disc is a type LD rupture disc with a vacuum support installed on the process side of the rupture disc.



LPL RUPTURE DISC

An LPL Rupture Disc incorporates a fluoropolymer outlet liner and process side seal for added protection against corrosion or product build up. This rupture disc typically consists of a fluoropolymer outlet liner, metallic top section and fluoropolymer seal on the process side.



LPLV RUPTURE DISC

An LPLV Rupture Disc is like the LPL Rupture Disc, but additionally will withstand full vacuum. It is usually constructed of a fluoropolymer outlet liner, metallic vacuum support, metallic top section and fluoropolymer seal on the process side. Positioning fluoropolymer material on both the inlet and outlet sides helps protect the vacuum support and top section from corrosive media and reduces product build up.

LAYER IDENTIFICATION EXAMPLE (LD OR LDV)

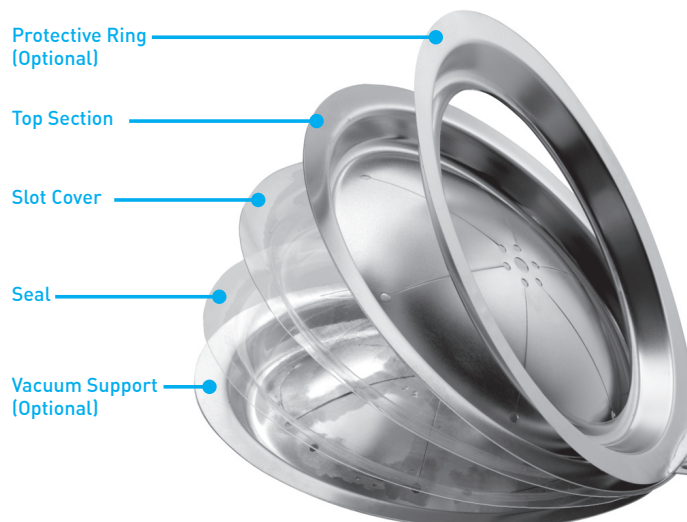

Table 4 // Minimum/Maximum Burst Pressures for Standard Rupture Discs at 72°F (22° C)

Rupture Disc Nominal Size	Minimum Burst Pressure						Standard Rupture Disc Minimum Burst Pressure with a Fluoropolymer Liner (Add to Rupture Disc Minimum Burst Pressure)		Protective Ring: When Burst Pressure is Less Than Value Stated Below, A Protective Ring is Recommended					
	Aluminum	MONEL®	Nickel	INCONEL®	316 SS	HASTELLOY® C	Inlet or Outlet Only	Both Inlet & Outlet	Aluminum	MONEL®	Nickel	INCONEL®	316 SS	HASTELLOY® C
¼ in	160	700	600	970	1550	1550	-	-	-	-	-	-	-	-
6 mm	11,0	48,3	41,4	66,9	107	107	-	-	-	-	-	-	-	-
½ in	65	350	300	560	760	760	150	300	520	3,000	2,290	3,600	3,700	5,300
13 mm	4,48	24,1	20,7	38,6	52,4	52,4	10,3	20,7	35,9	207	158	248	255	-
1 in	29	180	150	250	420	420	50	100	260	1,500	1,145	1,800	1,830	2,670
25 mm	2,00	12,4	10,3	17,2	29,0	29,0	3,45	6,90	18,0	103	78,9	124	126	-
1 ½ in	22	116	100	150	275	275	35	70	180	1,030	790	1,240	1,255	1,780
40 mm	1,52	8,00	6,90	10,3	19,0	19,0	2,41	4,83	12,4	71,0	54,4	85,5	86,5	-
2 in	13	70	60	110	150	150	25	50	110	635	485	760	775	1,300
50 mm	0,896	4,83	4,14	7,58	10,3	10,3	1,72	3,45	7,58	43,8	33,4	52,4	53,4	-
3 in	10	50	45	80	117	117	15	30	75	445	340	535	545	890
80 mm	0,690	3,45	3,10	5,52	8,07	8,07	1,03	20,7	5,17	30,7	23,4	36,9	37,6	-
4 in	7	40	35	70	90	90	11	22	60	350	270	420	430	670
100 mm	0,483	2,76	2,41	4,83	6,21	6,21	0,759	1,52	4,14	24,1	18,6	29,0	29,6	-
6 in	5	30	25	47	62	62	8	16	45	260	200	315	320	445
150 mm	0,345	2,07	1,72	3,24	4,27	4,27	0,552	1,10	3,10	17,9	13,8	21,7	22,1	-
8 in	4	23	20	34	51	51	6	12	35	200	155	240	245	330
200 mm	0,276	1,59	1,38	2,34	3,52	3,52	0,414	0,827	2,41	13,8	10,7	16,5	16,9	-
10 in	4	17	16	30	43	43	5	10	28	160	125	195	200	270
250 mm	0,276	1,17	1,10	2,07	2,96	2,96	0,345	0,690	1,93	11,0	8,62	13,4	13,8	-
12 in	3	15	13	25	36	36	4	8	24	135	105	160	165	220
300 mm	0,207	1,03	0,900	2,14	2,48	2,48	0,276	0,552	1,65	9,31	7,24	11,0	11,4	-

Table 5 // Minimum/Maximum Burst Pressures for Preformed Composite Rupture Discs at 72°F (22° C)

Rupture Disc Nominal Size	Minimum Pressure for Preformed Composite Rupture Discs with a Fluoropolymer Seal							
	LD		LDV		LPL		LPVL	
	TFE	FEP, PFA	TFE	FEP, PFA	TFE	FEP, PFA	TFE	FEP, PFA
1 in	25	30	30	35	35	40	60	80
25 mm	1,73	2,07	2,07	2,42	2,42	2,76	4,14	5,52
1 ½ in	22	27	25	34	32	38	60	75
40 mm	1,52	1,87	1,73	2,35	2,21	2,63	4,14	5,18
2 in	7	15	10	18	15	20	28	35
50 mm	0,483	1,04	0,690	1,25	1,04	1,38	1,94	2,42
3 in	6	8	8	11	11	16	18	25
80 mm	0,414	0,552	0,552	0,759	0,759	1,11	1,25	1,73
4 in	5	7	7	8	6	9	15	18
100 mm	0,345	0,483	0,483	0,552	0,414	0,621	1,04	1,25
6 in	3	4	5	7	5	7	12	14
150 mm	0,207	0,276	0,345	0,483	0,345	0,483	0,828	0,966
8 in	2	3	5	5	4	5	11	11
200 mm	0,138	0,207	0,345	0,345	0,276	0,345	0,759	0,759
10 in	-	3	-	5	-	5	-	8
250 mm	-	0,207	-	0,345	-	0,345	-	0,552
12 in	-	2	-	4	-	5	-	8
300 mm	-	0,138	-	0,276	-	0,345	-	0,552

White bars indicate 'psig'. Grey bars indicate 'barg'.

Maximum Burst Pressure						Maximum Burst Pressure With Fluoropolymer Liners						Rupture Disc Nominal Size
Aluminum	MONEL®	Nickel	INCONEL®	316 SS	HASTELLOY® C	Aluminum	MONEL®	Nickel	INCONEL®	316 SS	HASTELLOY® C	
2,000	60,000	60,000	33,500	60,000	60,000	-	-	-	-	-	-	¼ in
138	4,137	4,137	2,310	4,137	4,137	-	-	-	-	-	-	6 mm
1,500	6,000	6,000	6,000	6,000	6,000	1,500	6,000	6,000	6,000	6,000	6,000	½ in
103	414	414	414	414	414	103	414	414	414	414	414	13 mm
1,000	6,000	6,000	6,000	6,000	6,000	1,000	3,000	3,000	5,000	5,000	5,000	1 in
68,9	414	414	414	414	414	68,9	207	207	345	345	345	25 mm
750	6,000	6,000	6,000	6,000	6,000	700	2,000	2,000	3,400	3,400	3,400	1 ½ in
51,7	414	414	414	414	414	48,3	138	138	234	234	234	40 mm
570	4,500	4,000	6,000	6,000	6,000	500	1,300	1,300	1,800	1,800	1,800	2 in
39,3	310	276	414	414	414	34,5	89,6	89,6	124	124	124	50 mm
460	3,200	2,500	4,000	6,000	6,000	400	900	900	1,500	1,500	1,500	3 in
31,7	221	172	276	414	414	27,6	62,1	62,1	103	103	103	80 mm
360	2,400	1,900	3,000	6,000	3,600	325	650	650	1,100	1,100	1,100	4 in
24,8	165	131	207	414	-	22,4	44,8	44,8	75,8	75,8	75,8	100 mm
275	1,800	1,400	2,200	3,600	3,600	240	500	500	800	800	800	6 in
19,0	124	96,5	152	248	248	16,5	34,5	34,5	55,2	55,2	55,2	150 mm
205	1,450	1,100	1,700	2,100	2,100	180	375	375	600	600	600	8 in
14,1	100	75,8	117	145	145	12,4	25,9	25,9	41,4	41,4	41,4	200 mm
165	1,150	800	1,400	1,400	1,440	135	300	300	500	500	500	10 in
11,4	79,3	55,2	96,5	96,5	96,5	9,31	20,7	20,7	34,5	34,5	34,5	250 mm
140	960	670	1,000	1,000	1,000	110	250	250	400	400	400	12 in
9,65	66,2	46,2	68,9	68,9	68,9	7,58	17,2	17,2	27,6	27,6	2,76	300 mm

White bars indicate 'psig'. Grey bars indicate 'barg'.

Minimum Pressure for Preformed Composite Rupture Discs with Metallic Seal For LD, LDV Type Discs						Maximum Pressure for Composite Rupture Discs with:		Rupture Disc Nominal Size
Aluminum	MONEL®	Nickel	INCONEL®	316 SS	HASTELLOY® C	Fluoropolymer Seal	Metallic Seal	
38	190	230	292	442	1,163	500	1,440	1 in
2,63	13,1	15,9	20,2	30,5	802	34,5	99,3	25 mm
29	130	150	208	228	775	500	1,440	1 ½ in
2,00	8,97	10,4	14,4	15,8	53,4	34,5	99,3	40 mm
17	78	90	124	208	465	290	1,100	2 in
1,18	5,38	6,21	8,55	14,4	32,1	20,0	75,8	50 mm
13	59	65	98	130	326	160	900	3 in
0,897	4,07	4,49	6,76	8,97	22,5	11,0	62,0	80 mm
9	46	52	72	98	255	160	720	4 in
0,621	3,18	3,59	4,97	6,76	17,6	11,0	49,6	100 mm
7	33	39	56	65	191	130	640	6 in
0,483	2,28	2,69	3,87	4,49	13,2	8,97	44,1	150 mm
5	26	30	39	52	145	110	590	8 in
0,345	1,80	2,07	2,69	3,59	10,0	7,59	40,6	200 mm
5	21	22	33	46	113	90	480	10 in
0,345	1,45	1,52	2,28	3,18	7,79	6,21	33,0	250 mm
4	17	20	29	39	97	80	400	12 in
0,276	1,18	1,38	2,00	2,69	6,69	5,52	27,5	300 mm

NOTES: 1. Minimum & maximum pressures stated are based upon the minimum & maximum of the manufacturing range at 72°F (22°C). 2. For information concerning conditions or a size not shown, consult the factory.

RUPTURE
DISC
TABLES
//
LDV-G
STD
"IS"

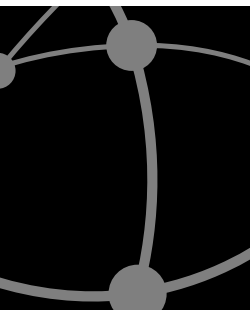

TABLES

Table 6 // Minimum/Maximum Burst Pressures for Rupture Discs in Screw Type & Throwaway Holders

Subject to holder maximum rating

Rupture Disc Type	Available Holder Assemblies	Rupture Disc Material	Burst Pressure Minimum/Maximum (72° F / 22° C)			
			Minimum		Maximum	
			psig	barg	psig	barg
11/16" LDV-G with Fluoropolymer Seal	Throwaway & Screw Type Assemblies	Nickel	30	2,07	490	33,8
		MONEL®	30	2,07	615	42,4
		316 SS	40	2,76	740	51,0
		INCONEL®	40	2,76	760	52,4
		HASTELLOY® C	100	6,89	1,000	68,9
1/2" Standard 11/16" Standard	Throwaway (to 3,000 psig) & Screw Type Assemblies	Aluminum	65	4,48	1,500	103
		HASTELLOY® C	760	52,4	15,000	1034
		Nickel	300	20,7	6,000	414
		MONEL®	350	24,1	6,000	414
		316 SS	760	52,4	15,000	1034
		INCONEL®	560	38,6	15,000	1034
3/4" Standard	Throwaway Assembly (1,000 psig only)	Aluminum	47	3,24	1,000	68,9
		HASTELLOY® C	590	-	1,000	68,9
		Nickel	225	15,5	1,000	68,9
		MONEL®	265	18,3	1,000	68,9
		316 SS	590	40,7	1,000	68,9
		INCONEL®	405	27,9	1,000	68,9
1" Standard	Throwaway Assembly (1,000 psig only)	Aluminum	29	2,00	1,000	68,9
		HASTELLOY® C	420	29,0	1,000	68,9
		Nickel	140	9,65	1,000	68,9
		MONEL®	180	12,4	1,000	68,9
		316 SS	360	24,8	1,000	68,9
		INCONEL®	250	17,2	1,000	68,9

Table 7 // Minimum/Maximum Burst Pressures for "IS" Rupture Discs

Rupture Disc Nominal Size	Burst Pressure Minimum/Maximum (72° F / 22° C)	
	Minimum Burst Pressure	Maximum Burst Pressure
1"	15	59
25mm	1,03	4,07
1 1/2"	10	59
40mm	0,689	4,07
2"	6	59
50mm	0,414	4,07
2 1/2"	5	59
65mm	0,345	4,07
3"	4	59
80mm	0,279	4,07
3 1/2"	3.5	59
90mm	0,241	4,07
4"	3	59
100mm	0,207	4,07
6"	2	59
150mm	0,138	4,07
8"	1.6	59
200mm	0,110	4,07
10"	1.2	59
250mm	0,083	4,07
12"	1	59
300mm	0,069	4,07

NOTES:

1. White bars indicate 'psig'. Grey bars indicate 'barg'
2. Minimum & maximum pressures stated are based upon the minimum & maximum of the manufacturing range at 72°F (22°C)

ALARM SYSTEMS

ALARM SYSTEMS



BDI-FLX® BURST DISC SENSOR SYSTEM



B.D.I.® ALARM SYSTEM

Continental Disc Corporation provides two systems for monitoring the burst of a rupture disc, the BDI-FLX® Sensor System and the B.D.I.® Alarm System. Common features include:

- Detects venting, provides instantaneous notification of the bursting of a rupture disc
- Signals emergency equipment, control room and/or operating personnel to alter or stop a process
- Can be combined with a CDC Alarm Monitor to protect equipment, lives and the environment

The **BDI-FLX® Burst Disc Sensor System** provides many benefits, which include:

- Allows direct interface to PLC's, DCS (Distributed Control System), alarm monitors or isolating barriers and can provide dry contacts for industrial controls
- Improved durability:
 - The conductive element is fully encapsulated in corrosive resistant polyimide film
 - The advanced technologies of the sensor strip minimize the risk of damage due to excessive stress beyond recommended bolting load
 - The alignment ring provides a rigid support for the new sensor cable, minimizing cable strain
- Modernized output cable connectors in accordance with IEC 61076-2-101 IP67 rated M12 connector



FOR MORE INFORMATION ON OUR BDI-FLX BURST DISC SENSOR SYSTEM, PLEASE SEE THE: [BDI-FLX BURST DISC SENSOR SYSTEM DATASHEET](#)

The **B.D.I.® Alarm System** provides many benefits, which include:

- Expanded availability in sizes up to 36" (900mm)
- Available as integral design to many rupture disc and vent panel products



FOR MORE INFORMATION ON OUR B.D.I. ALARM SYSTEM, PLEASE SEE THE: [B.D.I. ALARM SYSTEM DATASHEET](#)

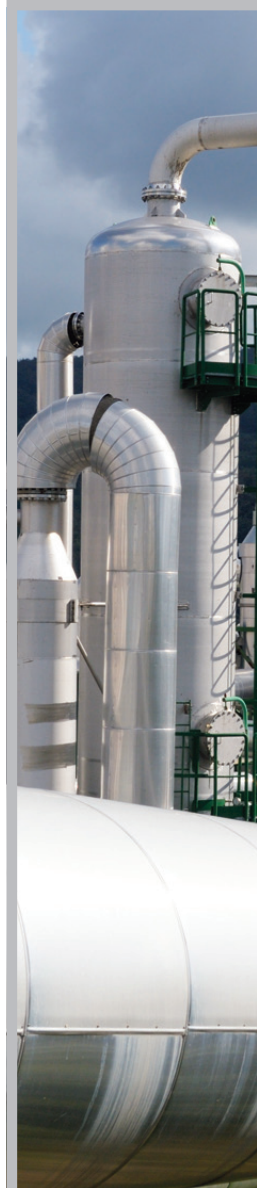
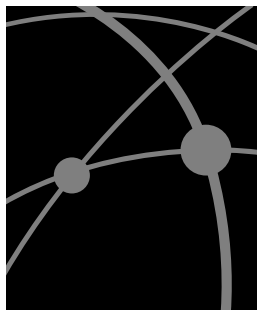

RUPTURE DISC HOLDERS

RUPTURE DISC HOLDERS

LaMOT Brand rupture disc holders are offered in a variety of types and styles to meet customers' needs. The basic holder is two pieces, consisting of an inlet and an outlet.

The seating surface of each piece is machined to grip a specific type rupture disc and when assembled together with the rupture disc, forms a gasket seal. Both the 30° seat and flat seat design are machined to industry standards. Corrosion resistance can be enhanced by utilization of fluoropolymer coating of the holder inlet and/or outlet.

The five types of rupture disc holders offered include:

- Insert
- Full Bolted
- Union
- Throwaway
- Screw Type

TAGGING

Both full bolted and insert holders are supplied with a permanently attached stainless steel nameplate indicating flow direction. A three dimensional stainless steel flow direction tag is attached to the rupture disc. Directional arrows on the tags and nameplates provide immediate visual verification that the holder and rupture disc assembly have been properly oriented in the system. In addition, whenever specific holder identification tagging is required, a stainless steel Customer Identification Tag is attached.



HOLDER ACCESSORIES

STUDS AND NUTS of the appropriate length to engage the rupture disc insert holder with an inlet and outlet flange are available in alloy steel¹ or 316 SS² materials.

JACKSCREWS, alloy steel: 3 per set

EYEBOLTS, carbon steel

CLEANING FOR OXYGEN or **CHLORINE SERVICE**

TELL-TALE INDICATOR components between any two inline pressure relief devices can include the following:

- Gauge taps in the holder outlet: 1/4", 3/8" or 1/2" NPT (tap size, location & type may impact holder height)
- Pipe nipples & tees, CS or SS: 1/4", 3/8" or 1/2" NPT
- Excess Flow Valve, 316 SS: 1/4" or 1/2" NPT
- Pressure Gauges



¹ ASME SA-193-B7 studs, SA-194-2H nuts

² ASME SA-193-B8M Class 2 studs, SA-194-8M nuts

RUPTURE DISC HOLDERS



INSERT HOLDERS

The Insert Holder is a 30° seat holder which fits within the bolting pattern of ASME, DIN or JIS companion pipe flanges. Insert Holders are furnished with pre-assembly cap screws or clips for bench assembly. Installation of the holder is easy. These holders are designed to be used with either Standard or Composite 30° Seat (LL) or (HL) Rupture Discs.

The Insert Holder is available in nominal sizes ranging from 1/2" through 12" (13 - 300 mm) to mate with ASME bolting classes 150# through 2500# and corresponding DIN or JIS flanges. Standard materials of construction include carbon steel and 316 SS. Other materials are available upon request. Refer to [Table 9](#) for holder dimensions.



FULL BOLTED HOLDERS

The LaMOT Brand offers nine connection combinations of full bolted holders compatible with ASME, DIN or JIS bolting classes. Full bolted holders are available in any combination of welded, threaded or flat faced inlet and outlet connections. These holders are designed to be used with either Standard or Composite 30° Seat (LL) or (HL) Rupture Discs.

The full bolted holder is available in nominal sizes ranging from 1/2" through 12" (13 - 300 mm) to mate with ASME bolting classes 150# through 2500#. Standard materials of construction include carbon steel and/or 316 SS. Other materials are available upon request. Refer to [Tables 10 & 11](#) for dimensions and connection combinations.



UNION HOLDERS

The Union Type Holder is designed to provide flexibility of use in tight piping configurations. These precisely built holders combine remarkable ease of installation with high pressure ratings in pipe sizes of 2" (50 mm) or less. These holders are designed to be used with either Standard or Composite (LL) Rupture Discs. Standard sizes, ratings and bores are shown in [Table 13](#). Contact the factory for applications outside this range. Any combination of welded or threaded connections is available. All parts are available in Carbon Steel and 316 SS. The units are designed with 30° angular seating. Identification of size, pressure rating and flow direction is laser marked on the assembly. Refer to [Tables 4 & 5](#) for rupture disc details.

If the unit has a threaded outlet, it can be supplied with a muffled plug. This reduces reaction forces upon disc rupture, and redirects fragments or product from dispersing directly from the nozzle. For more information on the muffled plug, contact the factory.

The Wing Nut/Hammer Nut Union Holder is supplied with extra heavy hammer lugs. This design is a favorite of field personnel who must replace rupture discs in hard to reach locations.

LaMOT wing nut Union Holders are available in sizes 1", 1½" and 2". They have coarse threaded nuts and subs for maximum strength and easy assembly.

Hex Nut Union Holders are available in sizes ½", 1", 1½" and 2".

Union Holders are supplied in standard materials of Carbon Steel and/or Stainless Steel. Other materials are available upon request. Refer to [Table 13](#) for dimensions and holder ratings.

As a standard, rupture discs for use in Union Type Holders are shipped with a detached tag, which should be affixed to the completed assembly when the rupture disc is installed.

For those requiring positive identification of rupture disc installations, a special Union Type Holder allows the installation of a rupture disc with a permanently attached 3-dimensional flow direction tag. The 3-D flow tag extends beyond the holder for easier verification of orientation after the rupture disc has been installed (not available in 2" 2000# configuration).

When ordering rupture discs, please state whether the disc is to be installed in a Union Type Holder, and whether you require the standard configuration or a permanently attached 3-D flow tag.

RUPTURE DISC HOLDERS

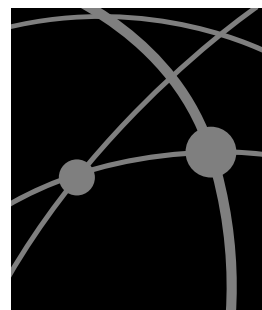

HOLDER
TABLES
//
30°
INSERT
HOLDERS

Table 9 // 30° Insert Holder Weights and Dimensions

Nominal Size	ASME		DIN		JIS		Height (in/mm)	Weight (lbs/kg)
	Class	Outside Dia. (in/mm)	Class	Outside Dia. (mm)	Class	Outside Dia. (mm)		
¼ in 13 mm	150	1.75/44,5					1.67/42	1.0/0,45
	300/600	2.00/50,8					1.67/42	1.4/0,64
	900/1500	2.38/60,3					1.86/47	2.3/1,0
1 in 25 mm	150	2.50/63,5					1.67/42	1.9/0,90
	300/600	2.75/69,9	10/40	69,9	10/20	69,9	1.67/42	2.5/1,1
					30/40	76,0	1.67/42	2.9/1,3
			64/160	82,0			2.38/60	4.9/2,2
			250	82,0			2.38/60	4.9/2,2
	900/1500	3.00/76,2					2.38/60	4.1/1,9
1 ½ in 40 mm	150	3.25/82,6					1.67/42	3.0/1,4
					10/20	86,0	1.67/42	3.4/1,5
	300/600	3.63/92,2	10/40	92,2			1.67/42	4.0/1,8
	900/1500	3.75/95,3					2.66/68	6.9/2,7
					30/40	97,0	1.67/42	4.5/2,0
			64/160	102,0			2.66/68	8.1/3,7
2 in 50 mm			250	108,0			2.66/68	10/4,5
	150	4.00/101,6			10	101,6	1.67/42	3.6/1,6
					16/20	101,6	1.67/42	3.6/1,6
	300/600	4.25/108,0	10/40	108,0			1.67/42	4.3/2,0
			64	111,0	30/40	111,0	1.67/42	4.8/2,2
			100/160	118,0			3.15/80	11/5,0
3 in 80 mm			250	123,0			3.15/80	13/5,9
	900/1500	5.50/139,7					3.15/80	17/7,8
					10	131,0	1.67/42	5.2/2,4
	150	5.25/133,4					1.67/42	5.5/2,5
					16/20	137,0	1.67/42	6.1/2,8
			10	142,0			2.13/54	8.9/4,0
4 in 100 mm			16/40	142,0			2.13/54	8.9/4,0
			64	146,1	30/40	146,1	2.13/54	10/4,5
	300/600	5.75/146,1	100/160	153,0			3.21/82	19/8,6
							3.21/82	23/10
	900	6.50/165,1	250	170,0			3.71/94	29/13
							3.71/94	29/13
6 in 150 mm	1500	6.75/171,5					3.71/94	29/13
					10	156,0	1.67/42	6.0/2,7
			10/16	162,0	16/20	162,0	1.67/42	7.4/3,4
			25/40	168,0	30	168,0	2.15/55	12/5,4
	150	6.75/171,5					1.67/42	9.1/4,1
			64	173,0			3.13/79	18/8,3
8 in 200 mm	300	7.00/177,8					2.15/55	13/5,9
					40	180,0	2.15/55	14/6,4
			100/160	180,0			3.63/92	26/12
							3.13/79	25/11
	600	7.50/190,5	250	202,0			4.35/111	45/20
							3.63/92	37/17
10 in 250 mm	900	8.00/203,2					3.63/92	37/17
	1500	8.13/206,5					4.35/111	47/22
			10/16	217,0	10	217,0	2.06/52	16/7,2
			25/40	223,0			2.06/52	17/7,7
	150	8.63/219,2					2.93/74	26/12
					16/20	235,0	2.06/52	22/9,7
12 in 300 mm	300	9.75/247,7	64	247,0	30	247,7	3.96/101	55/25
			100/160	257,0			2.93/74	37/17
					40	262,0	4.53/115	71/32
							2.93/74	44/20
	600	10.38/263,7					3.96/101	66/30
	900	11.25/285,8					4.53/115	95/43
14 in 350 mm					10	267,0	2.31/58	25/11
			10/16	272,0			2.31/58	27/12
	150	10.88/276,4					2.31/58	29/13
					16/20	280,0	2.31/58	31/14
			25	283,0			3.30/84	44/20
			40	290,0			3.30/84	48/22
16 in 400 mm					30	293,0	3.30/84	50/23
	300	12.00/304,8					3.30/84	58/26
			64	309,0			4.50/114	83/38
					40	312,0	3.30/84	63/29
	600	12.50/317,5					4.50/114	91/41
			10/16	327,0			2.55/65	34/15
18 in 450 mm					10	330,0	2.55/65	36/16
	150	13.25/336,6					2.55/65	40/18
			25	340,0			4.18/106	69/31
			40	352,0			4.18/106	81/37
					16/20	353,0	2.55/65	49/22
					30	357,0	4.18/106	86/39
20 in 500 mm	300	14.13/358,9					4.18/106	88/40
			64	364,0			5.00/127	128/58
					40	377,0	4.18/106	107/49
			100	391,0			5.00/127	163/74
	600	15.63/397,0					5.00/127	171/78
24 in 600 mm					5	367,0	2.55/65	36/16
					10	375,0	2.55/65	41/19
			10	377,0			2.55/65	42/19
			16	383,0			2.55/65	46/21
			25	400,0			4.13/105	94/43
					16/20	403,0	2.55/65	60/27
30 in 750 mm	150	16.00/406,4					2.55/65	62/28
			40	417,0	30	417,0	4.13/105	114/52
	300	16.50/419,1					4.13/105	116/53
			64	424,0			5.43/138	161/73
					40	431,0	4.13/105	130/59
	600	17.88/454,2					5.43/138	211/96

NOTES: Consult factory for availability of flange classes or sizes not listed. // Gauge taps and facing options could affect the holder height and weight.

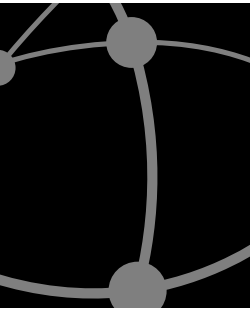

HOLDER
TABLES
//
FULL
BOLTED
HOLDERS

Table 10 // Full Bolted Holder Assembly Number and Connections

Assembly Number	Connections	
	Inlet	Outlet
1	Threaded	Flat Face
2	Threaded	Threaded
3	Threaded	Weldneck
4	Weldneck	Flat Face
5	Weldneck	Threaded
6	Weldneck	Weldneck
7	Flat Face	Flat Face
8	Flat Face	Threaded
9	Flat Face	Weldneck

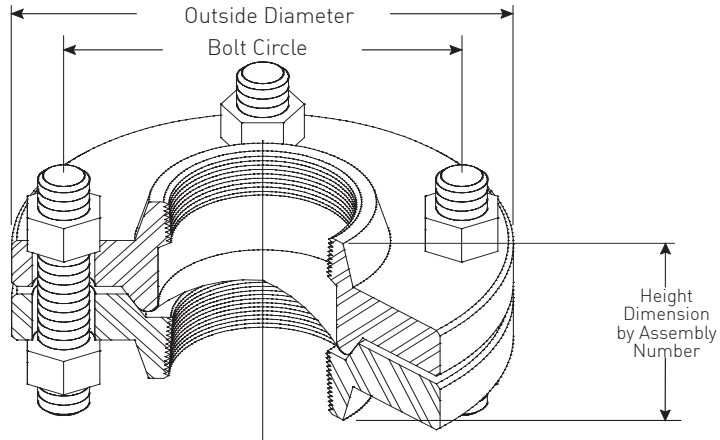

Table 11 // Full Bolted Holder Assembly Dimensions

All dimensions in inches. See drawing above.

NOMINAL SIZE	ASME Class	Outside Diameter	Bolt Circle	Studs		Height Dimension of Full Bolted Assembly Number								
				No.	Diameter	#1	#2	#3	#4	#5	#6	#7	#8	#9
1/2 in	150	3.50	2.38	4	.50	2.20	2.38	3.13	2.81	3.00	3.75	1.75	1.88	2.63
	300	3.75	2.63	4	.50	2.00	2.63	3.50	2.88	3.50	4.38	1.69	1.75	2.63
	600	3.75	2.63	4	.50	2.00	2.63	3.50	2.88	3.50	4.38	1.69	1.75	2.63
	900/1500	4.75	3.25	4	.75	5.56	3.38	4.06	3.38	4.19	4.88	1.88	2.69	3.38
1 in	150	4.25	3.13	4	.50	1.94	2.78	3.56	2.75	3.59	4.38	1.13	1.97	2.75
	300	4.88	3.50	4	.63	2.25	2.97	4.00	3.13	3.84	4.88	1.38	2.09	3.13
	600	4.88	3.50	4	.63	2.38	3.10	4.13	3.25	3.97	5.00	1.50	2.22	3.25
	900/1500	5.88	4.00	4	.88	3.00	3.59	4.75	4.13	4.72	5.88	2.38	2.97	4.13
1 1/2 in	150	5.00	3.88	4	.50	2.25	3.03	4.00	3.13	3.91	4.88	1.38	2.16	3.13
	300	6.13	4.50	4	.75	2.13	2.84	4.00	3.50	4.22	5.38	1.63	2.34	3.50
	600	6.13	4.50	4	.75	2.38	3.09	4.25	3.75	4.47	5.63	1.88	2.59	3.75
	900/1500	7.00	4.88	4	1.00	3.13	3.66	5.13	4.63	5.66	7.13	2.50	3.00	4.50
2 in	150	6.00	4.75	4	.63	2.13	2.97	3.88	3.25	4.10	5.00	1.50	2.35	3.25
	300	6.50	5.00	8	.63	2.44	3.16	4.31	3.63	4.35	5.50	1.75	2.47	3.63
	600	6.50	5.00	8	.63	2.81	3.53	4.69	4.00	4.72	5.88	2.13	2.84	4.00
	900/1500	8.50	6.50	8	.88	3.88	4.63	6.38	5.63	6.38	8.13	3.13	3.88	5.63
3 in	150	7.50	6.00	4	.63	2.56	3.09	4.44	3.75	4.28	5.63	1.88	2.41	3.75
	300	8.25	6.63	8	.75	2.94	3.59	4.94	4.25	4.91	6.25	2.25	2.91	4.25
	600	8.25	6.63	8	.75	3.19	3.85	5.19	4.63	5.28	6.63	2.63	3.28	4.63
	900	9.50	7.50	8	.88	4.00	4.50	6.25	5.75	6.38	8.13	3.00	3.50	5.50
4 in	150	9.00	7.50	8	.63	2.75	3.72	4.88	4.00	4.97	6.13	1.88	2.84	4.00
	300	10.00	7.88	8	.75	3.56	4.34	5.69	4.69	5.47	6.81	2.50	3.28	4.63
	600	10.75	8.50	8	.88	3.88	4.50	5.97	5.63	6.38	7.72	3.13	3.75	5.22
	900	11.50	9.25	8	1.13	5.00	5.38	7.38	6.50	7.13	9.13	3.50	4.50	6.25
6 in	150	11.00	9.50	8	.75	3.25	4.09	5.56	4.75	5.59	7.06	2.19	3.03	4.50
	300	12.50	10.63	12	.75	3.50	4.13	6.50	5.31	5.94	7.88	2.88	3.50	5.06
	600	14.00	11.50	12	1.00	4.75	6.13	7.38	6.75	8.25	9.38	3.63	5.63	4.75
8 in	150	13.50	11.75	8	.75	4.00	5.25	6.88	5.19	6.44	8.06	2.25	3.50	5.13
	300	15.00	13.00	12	.88	4.25	5.38	7.00	6.25	7.25	8.88	3.25	4.75	6.00
10 in	150	16.00	14.25	12	.88	-	-	-	5.25	6.63	8.13	2.38	-	5.25
12 in	150	19.00	17.00	12	.88	2.63	-	4.75	5.75	7.38	7.94	2.50	-	5.69



HOLDER
TABLES
//
UNION
HOLDERS

Table 12 // Union Holder Assembly Number and Connections

Assembly Number	Connections	
	Inlet	Outlet
#2U	Threaded	Threaded
#3U	Threaded	Weldneck
#5U	Weldneck	Threaded
#6U	Weldneck	Weldneck

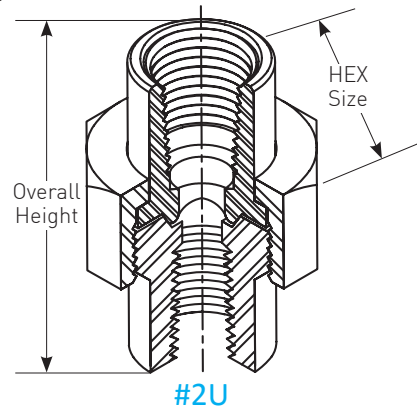
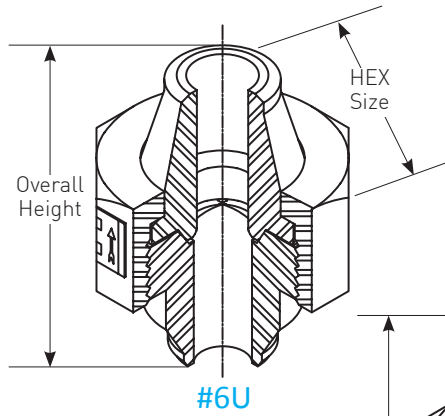
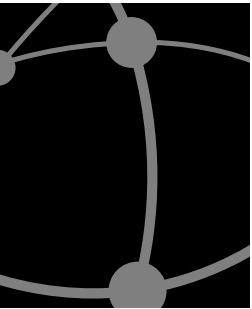

Table 13 // Union Holder Specifications

Size	Rating	Seat Design	Weldneck Bore	Hex Size	Overall Height			
					#2U	#3U	#5U	#6U
1/2 in 13 mm	3000#	UL	Schedule 80	1.75" 44,5 mm	2.75" 69,9 mm	2.50" 63,5 mm	2.55" 64,8 mm	2.30" 58,4 mm
	6000#	UH	Schedule 160	2.00" 50,8 mm	2.81" 71,4 mm	2.94" 74,7 mm	2.81" 71,4 mm	2.94" 74,7 mm
1 in 25 mm	2000#	UL	Schedule 80	2.50" 63,5 mm	3.24" 82,3 mm	2.93" 74,4 mm	2.93" 74,4 mm	2.63" 66,8 mm
	4000#	UL	Schedule 80	3.00" 76,2 mm	3.50" 88,9 mm	3.03" 77,0 mm	3.15" 80,0 mm	2.63" 66,8 mm
	6000#	UL	Schedule 160	3.00" 76,2 mm	3.50" 88,9 mm	3.03" 77,0 mm	3.15" 80,0 mm	2.63" 66,8 mm
1 1/2 in 40 mm	2000#	UL	Schedule 80	3.50" 88,9 mm	3.75" 95,3 mm	3.47" 88,1 mm	3.72" 94,5 mm	3.50" 88,9 mm
	4000#	UL	Schedule 80	3.50" 88,9 mm	3.75" 95,3 mm	3.47" 88,1 mm	3.72" 94,5 mm	3.50" 88,9 mm
2 in 50 mm	2000#	UL	Schedule 80	4.25" 108 mm	3.85" 97,8 mm	4.23" 107 mm	4.35" 110 mm	4.73" 120 mm
	4000#	UL	Schedule 160	5.00" 127 mm	5.13" 130 mm	4.85" 123 mm	5.10" 129 mm	5.13" 130 mm



RUPTURE DISC HOLDER ASSEMBLIES



SCREW TYPE HOLDER ASSEMBLY

The LaMOT Screw Type Assembly is a reusable unit for use in systems with pressures up to 15,000 psig [1,034 barg]. A Standard or Composite rupture disc (see [Table 6](#)) is supplied separately from the Screw Type Holder. After an overpressure condition occurs, changeout is accomplished by disassembling the Screw Type Holder and replacing only the burst rupture disc.

The Screw Type Assembly is a flat seat design and can be configured with a 1/2" Standard, 11/16" Standard or 11/16" Composite Flat Seat (FS) rupture disc. This assembly is used primarily for laboratory applications and in other small pressure vessels or systems.

The Screw Type Holder consists of three components:

- inlet
- holddown ring
- outlet

The inlet is available in 1/4", 3/8" and 1/2" male pipe threads (MPT). The outlet is available in 1/2" MPT, muffled or free configurations.

The Screw Type Holder is available with the inlet, outlet, and holddown ring made from brass or 316 SS. Specify the required material when ordering. Other materials will be quoted on request.

The 11/16" rupture disc with its matching holddown ring uses the same inlet and outlet holder as the 1/2" rupture disc with matching holddown ring. Refer to [Table 14](#) for Screw Type Holder specifications and dimensions.

Screw Type Holder Specifications

Maximum Pressure:	15,000 psig [1,034 barg]
Maximum Temperature:	1,000°F [538°C]
Materials:	All 316 SS Components

NOTE: A brass unit is available with a maximum pressure of 1,000 psig [68,9 barg] and a maximum temperature of 400°F [204°C].



THROWAWAY ASSEMBLY

The Throwaway Assembly is a sealed, disposable unit for use in systems where pressures do not exceed 3,000 psig [207 barg]. The assembly features a rupture disc sealed between brass fittings. After relieving an overpressure condition, change out is easily performed by replacing the entire assembly. The Throwaway Assembly can be supplied with a Standard or Composite rupture disc (see [Table 6](#)) to accommodate various application requirements.

Throwaway units are used on gas bottles, air conditioning systems, refrigeration units, hydraulic accumulators, gas cylinders, portable compressed air systems and laboratory equipment.

Two units are available:

- A 1,000 psig [68,9 barg] design is compatible with either a Standard or Composite rupture disc, up to a maximum 1,000 psig burst pressure
- For higher pressures, a 3,000 psig [207 barg] unit is available. It is compatible with a Standard Rupture Disc

The Throwaway unit, with a 1/2", 3/4" or 1" Standard or 11/16" Composite Flat Seat (FS) rupture disc, consists of three brass components:

- inlet
- holddown ring
- outlet

The inlet is available in 1/4", 3/8", 1/2", 3/4" or 1" male pipe threads (MPT). The outlet component is available in various configurations to match the requirement of your application (see [Tables 15 & 16](#)).

After the rupture disc is installed in the Throwaway Holder, the inlet and outlet components are permanently affixed to provide a sealed assembly. Each assembly is then inspected by a Beta Backscanner device to verify compliance to the proper rupture disc material thickness. When an overpressure condition occurs, the entire assembly can be quickly removed and replaced with a new assembly.

The maximum temperature limits of the Throwaway Holder are dependent upon the limitations of either the rupture disc or the holder. In the case of the maximum allowable temperature, use the lesser limit of the two.

Throwaway Holder Specifications

Maximum Pressure:	3,000 psig [207 barg]
Maximum Temperature:	400°F [204°C]
Materials:	All Brass Components

NOTE: At the factory's discretion, a fluoropolymer gasket may be added to the assembly.

RUPTURE DISC HOLDER ASSEMBLIES

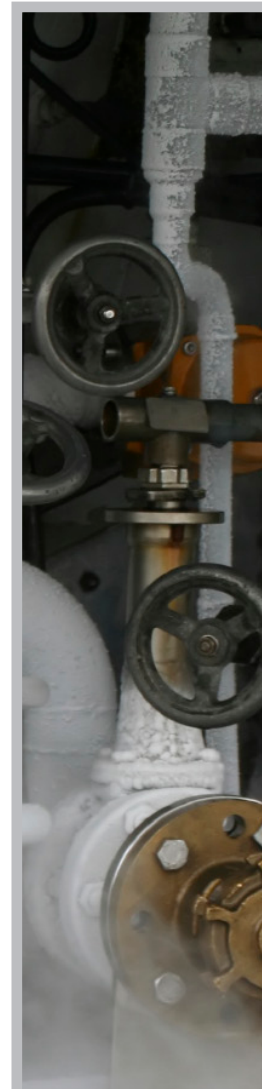
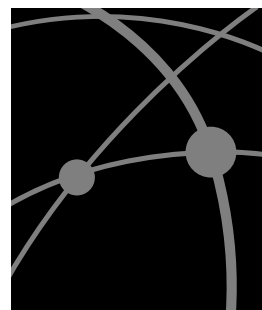

HOLDER TABLES // SCREW TYPE HOLDERS

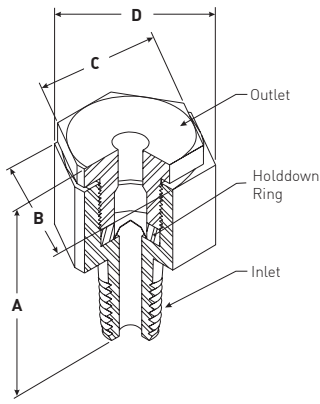

Free Outlet Assembly

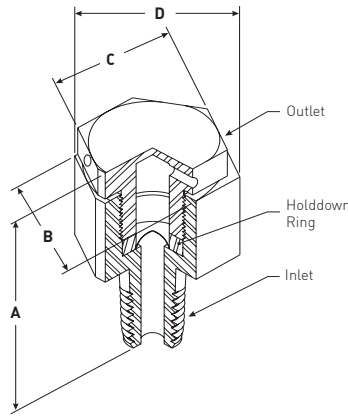

Muffled Outlet Assembly

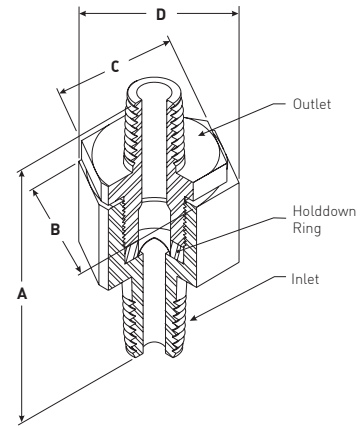

Threaded Outlet Assembly

Table 14 // Screw Type Holder Specifications and Dimensions

Holder Maximum		Holder Connection		Rupture Disc Size	Seat Design	Height (A) (in/mm)	Dimensions Across Hex Flats		Dimension Across Inlet Corners (D)
Pressure @ 72°F/22°C	Temp	Inlet	Outlet				Inlet (B)	Outlet (C)	
1,000 psig 68,9 barg	400°F 204°C	¼ MPT	Muffled	1 ¹ / ₁₆ "	FS	2.28 / 57,9	1 ¹ / ₄ in 31,8 mm	1 ¹ / ₈ in 28,6 mm	1.44 in 36,6 mm
		¾ MPT	Muffled	1 ¹ / ₁₆ "	FS	2.28 / 57,9			
		½ MPT	Muffled	1 ¹ / ₁₆ "	FS	2.28 / 57,9			
		¼ MPT	½ MPT	1 ¹ / ₁₆ "	FS	2.81 / 71,4			
		¾ MPT	½ MPT	1 ¹ / ₁₆ "	FS	2.81 / 71,4			
		½ MPT	½ MPT	1 ¹ / ₁₆ "	FS	2.81 / 71,4			
		¼ MPT	Free	1 ¹ / ₁₆ "	FS	2.03 / 51,6			
		¾ MPT	Free	1 ¹ / ₁₆ "	FS	2.19 / 55,6			
		½ MPT	Free	1 ¹ / ₁₆ "	FS	2.03 / 51,6			
3,000 psig 207 barg	1,000°F 538°C	¼ MPT	Muffled	1 ¹ / ₁₆ "	FS	2.28 / 57,9	1 ¹ / ₄ in 31,8 mm	1 ¹ / ₈ in 28,6 mm	1.44 in 36,6 mm
		¾ MPT	Muffled	1 ¹ / ₁₆ "	FS	2.28 / 57,9			
		½ MPT	Muffled	1 ¹ / ₁₆ "	FS	2.28 / 57,9			
		¼ MPT	½ MPT	1 ¹ / ₁₆ "	FS	2.81 / 71,4			
		¾ MPT	½ MPT	1 ¹ / ₁₆ "	FS	2.81 / 71,4			
		½ MPT	½ MPT	1 ¹ / ₁₆ "	FS	2.81 / 71,4			
		¼ MPT	Free	1 ¹ / ₁₆ "	FS	2.03 / 51,6			
		¾ MPT	Free	1 ¹ / ₁₆ "	FS	2.03 / 51,6			
		½ MPT	Free	1 ¹ / ₁₆ "	FS	2.03 / 51,6			
10,000 psig 689 barg	1,000°F 538°C	¼ MPT	Muffled	½"	FS	2.28 / 57,9	1 ¹ / ₄ in 31,8 mm	1 ¹ / ₈ in 28,6 mm	1.44 in 36,6 mm
		¾ MPT	Muffled	½"	FS	2.28 / 57,9			
		½ MPT	Muffled	½"	FS	2.28 / 57,9			
		¼ MPT	½ MPT	½"	FS	2.81 / 71,4			
		¾ MPT	½ MPT	½"	FS	2.81 / 71,4			
		½ MPT	½ MPT	½"	FS	2.81 / 71,4			
		¼ MPT	Free	½"	FS	2.03 / 51,6			
		¾ MPT	Free	½"	FS	2.03 / 51,6			
		½ MPT	Free	½"	FS	2.03 / 51,6			
15,000 psig 1,034 barg	1,000°F 538°C	¼ MPT	½ MPT	½"	HF	2.81 / 71,4	1 ¹ / ₄ in 31,8 mm	1 ¹ / ₈ in 28,6 mm	1.44 in 36,6 mm
		½ MPT	½ MPT	½"	HF	2.81 / 71,4			
		¼ MPT	Muffled	½"	HF	2.34 / 59,4			
		½ MPT	Muffled	½"	HF	2.34 / 59,4			

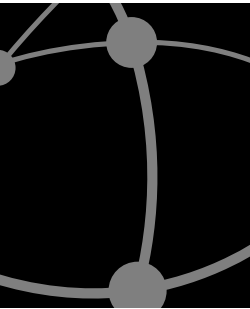

HOLDER TABLES // THROWAWAY HOLDERS

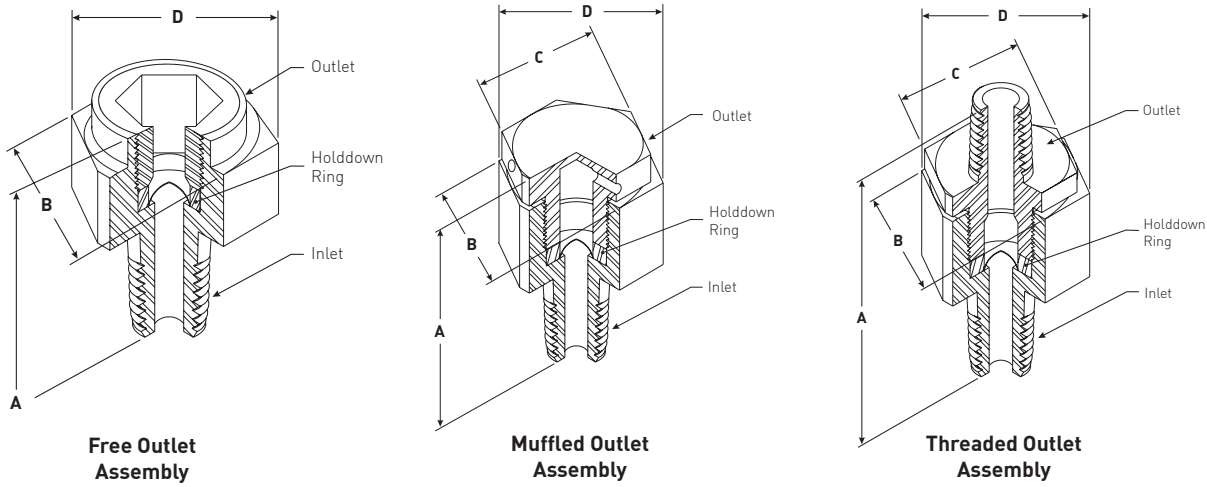
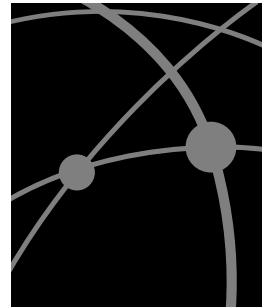

Table 15 // Throwaway Assembly Specifications and Dimensions for 1/2" or 11/16" Rupture Discs

Holder Connection		Unit Weight				Overall Height (A)				Dimension Across Hex Flats				Dimension Across Inlet Corners (D)	
Inlet	Outlet	1,000# Assembly		3,000# Assembly		1,000# Assembly		3,000# Assembly		Inlet (B)		Outlet (C)		1,000# Assembly	3,000# Assembly
		lbs	kgs	lbs	kgs	in	mm	in	mm	1,000# Assembly	3,000# Assembly	1,000# Assembly	3,000# Assembly		
¼ MPT	¼ MPT	0.27	0,12	0.32	0,15	2.12	54	2.27	58	1 ¼ in 28,6 mm	1 ¼ in 31,8 mm	1 in 25,4 mm	1 in 25,4 mm	1.30 in 33,0 mm	1.44 in 36,6 mm
¼ MPT	¾ MPT	0.28	0,13	0.33	0,15	2.16	55	2.31	59						
¼ MPT	½ MPT	0.30	0,14	0.35	0,16	2.31	59	2.45	62						
¼ MPT	Muffled	0.25	0,11	0.30	0,14	1.81	46	1.95	50						
¼ MPT	Free	0.20	0,09	0.25	0,11	1.34	34	1.49	38						
⅜ MPT	⅜ MPT	0.29	0,13	0.34	0,15	2.19	56	2.34	59	1 ¼ in 28,6 mm	1 ¼ in 31,8 mm	1 in 25,4 mm	1 in 25,4 mm	1.30 in 33,0 mm	1.44 in 36,6 mm
⅜ MPT	½ MPT	0.31	0,14	0.36	0,16	2.34	60	2.49	63						
⅜ MPT	Muffled	0.26	0,12	0.31	0,14	1.84	47	1.99	51						
⅜ MPT	Free	0.21	0,10	0.26	0,12	1.37	35	1.53	39						
½ MPT	½ MPT	0.34	0,15	0.39	0,18	2.50	63	2.50	64	1 ¼ in 28,6 mm	1 ¼ in 31,8 mm	1 in 25,4 mm	1 in 25,4 mm	1.30 in 33,0 mm	1.44 in 36,6 mm
½ MPT	Muffled	0.29	0,13	0.34	0,15	2.00	51	2.01	51						
½ MPT	Free	0.24	0,11	0.29	0,13	1.53	39	1.54	39						

Table 16 // Throwaway 1,000# Assembly Specifications and Dimensions for ¾" & 1" Rupture Discs

Holder Connection		Unit Weight		Overall Height (A)		Dimension Across Hex Flats		Dimension Across Inlet Corners (D)
Inlet	Outlet	lbs	kgs	in	mm	Inlet (B)	Outlet (C)	
¾ MPT	¾ MPT	0.37	0,17	2.51	63,8	1 ¼ in 31,8 mm	1 ¼ in 28,6 mm	1.44 in 36,6 mm
¾ MPT	Muffled	0.34	0,15	2.10	53,3			
¾ MPT	Free	0.29	0,13	1.73	43,9			
1 MPT	1 MPT	1.12	0,51	3.19	81,0	2 in 50,8mm	2in 50,8mm	2.31in 58,7mm
1 MPT	Muffled	1.24	0,56	2.50	63,5			
1 MPT	Free	1.12	0,51	2.25	57,2			



LAMOT[®]

BRAND PRODUCTS

A CONTINENTAL DISC CORPORATION BRAND



ASME Code Symbol Stamp
Available When Specified

China Manufacture License
Available on STD Rupture Discs
When Specified



Pressure Equipment Directive
Available When Specified

*HASTELLOY[®] is a registered trademark of Haynes International // INCONEL[®] and MONEL[®] are registered trademarks of the Inco family of companies
CHEMFILM[®] is a registered trademark of Saint-Gobain Performance Plastics Corporation*

LAMOT[®]
BRAND PRODUCTS

3160 W. Heartland Drive
Liberty, MO 64068 USA
Ph (816) 792 1500 // (281) 295 6800
Fax (816) 792 2277 // (281) 295 6950
sales@lamot.com

lamot.com



CONTINENTAL DISC CORPORATION //

3160 W. Heartland Drive
Liberty, MO 64068 USA
Ph (816) 792 1500 | Fax (816) 792 2277
sales@contdisc.com

GROTH CORPORATION //

13650 N. Promenade Blvd.
Stafford, TX 77477 USA
Ph (281) 295-6800 | Fax (281) 295-6999
sales@grothcorp.com